



High Power  
Universal Remote Tuner 1500  
(CHA URT1500)  
Operator's Manual

Nevada - USA

[WWW.CHAMELEONANTENNA.COM](http://WWW.CHAMELEONANTENNA.COM)



***VERSATILE – DEPENDABLE – STEALTH – BUILT TO LAST***

Rev. 1/10/2025

# Table of Contents

Introduction .....	3
Components.....	4
Installation Options.....	7
Antenna Configurations .....	9
Random Wire Antenna .....	9
Vertical Antenna .....	10
Coaxial Fed Inverted “V” Antenna .....	11
Tuner Connections.....	12
Tuner Operation.....	14
Tuning Notes:.....	14
Troubleshooting.....	15
Specifications .....	16
Chameleon Antenna™ Products.....	17



Be aware of overhead power lines when you are installing the CHA URT1500. You could be electrocuted if the antenna gets near or contacts overhead power lines.

Photographs and diagrams in this manual may vary slightly from current production units due to manufacturing changes that do not affect the form, fit, or function of the product.

All information on this product and the product itself is the property of and is proprietary to Chameleon Antenna™. Specifications are subject to change without prior notice.

## Introduction

Thank you for purchasing and using the Chameleon Antenna™ High Power Universal Remote Tuner 1500 (CHA URT1500). The CHA URT1500 is a high power remote outdoor tuner for almost any type of antenna and any brand or model transceiver. The CHA URT1500 is unique in that it can be used for coaxial cable or wire fed antennas. This High Frequency (HF) wide-range tuner will match wire antennas, such as a vertical, random wire antenna, or a long wire antenna. It can also be used with coaxial-fed antennas, like an Inverted “V” or dipole. Also, the CHA URT1500 does not need a transceiver-specific control cable, so it works with any brand or model of transceiver. The rugged Tuner Unit is weatherproof and designed to be permanently installed outdoors at or near the antenna feedpoint, so loss due to high SWR on the feedline is avoided. The CHA URT1500 covers 1.8 – 30.0 MHz and has 16,000 memories for quick recall and tuning with previously used settings. It can match any antenna with an impedance mismatch ratio of up to 16:1 within seconds. The CHA URT1500 can handle up to 1500 Watts on SSB/CW, 800 Watts on most digital and non-continuous duty cycle modes, and 400 Watts on AM, RTTY, WSPR and other similar continuous duty cycle modes.

The CHA URT1500 consists of two units: a Tuner Unit and the Coupler Unit. The Tuner Unit is in a rugged weatherproof housing and contains the antenna matching network and controller. It is normally installed outside at or near the antenna feedpoint. The Coupler Unit contains the operator controls and status indicators. It uses a bias-T circuit to send power and control signals to the remote Tuner Unit over the connecting coaxial cable, so there is no need to order or install a separate transceiver-specific control cable. The Coupler Unit is not weatherproof and must be installed inside near the operator and transceiver.

Please read this User Guide, so you may obtain the greatest utility from your CHA URT1500.

## Components

The components of the CHA URT1500 are shown in plate (1). The components are described in the paragraphs below. Two major components of the CHA URT1500 are the Tuner Unit and the Coupler Unit. The Coupler Unit is shown in plate (2). The Tuner Unit is shown in plate (3).

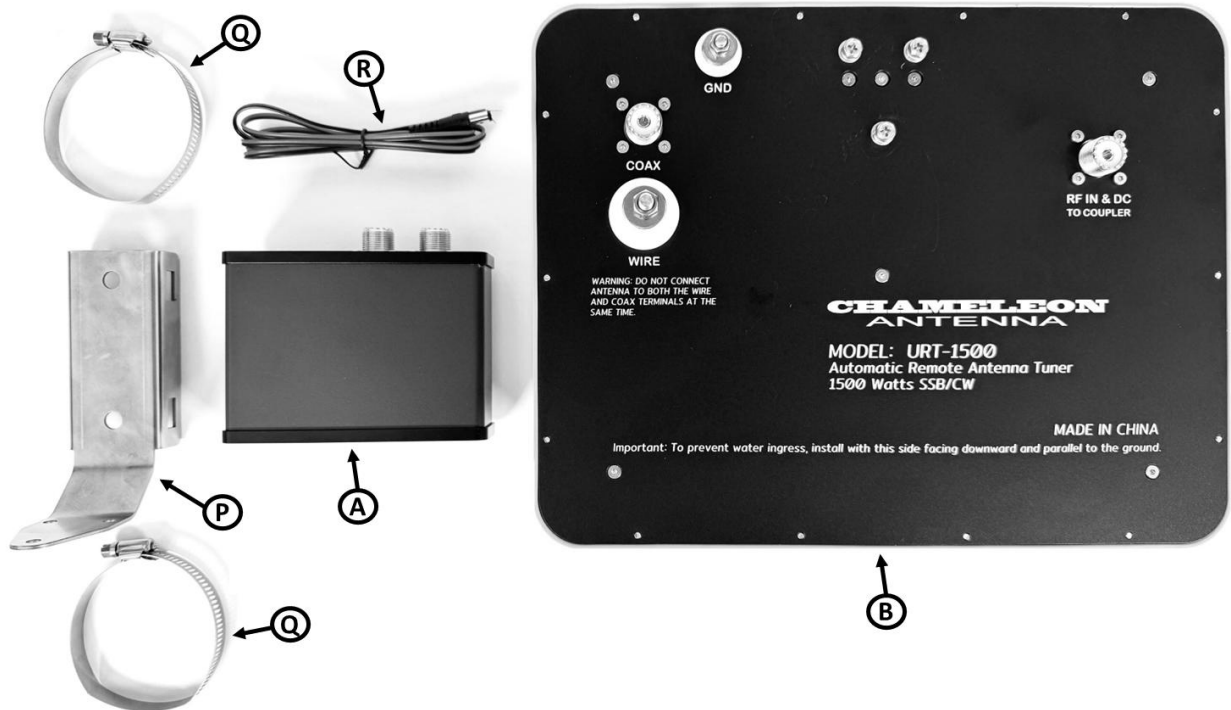
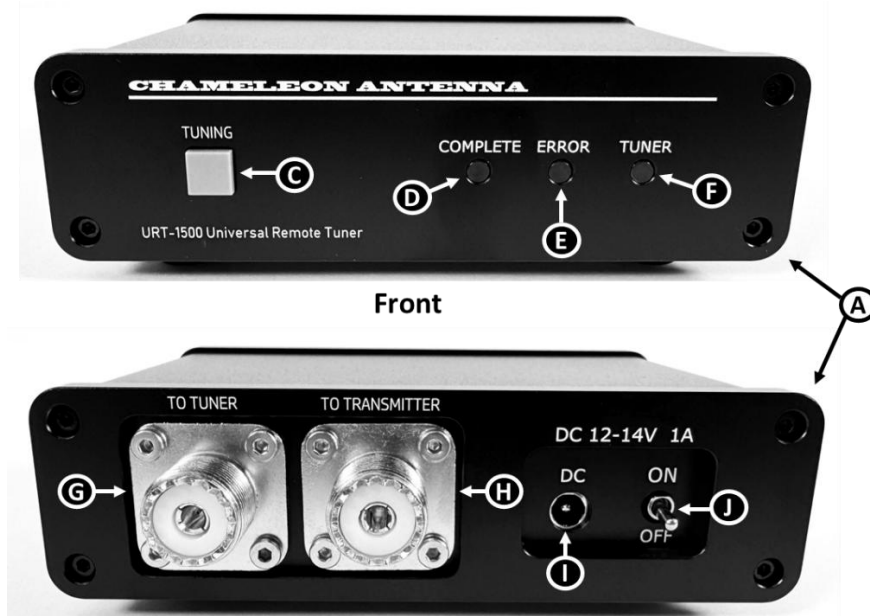

Plate 1. CHA URT1500 Components.



Back  
Plate 2. Coupler Unit.

- A. Coupler Unit.** The Coupler Unit serves as the bridge between the amplifier or transceiver and Tuner Unit. The Coupler Unit contains the operator controls and status indicators. It uses a bias-T circuit to send power and control signals to the remote Tuner Unit over the connecting coaxial cable. The Coupler Unit must be installed indoors near the transceiver.
- B. Tuner Unit.** The Tuner Unit contains the antenna matching network and controller. The Tuner Unit is in a rugged weatherproof housing and is normally installed outside at or near the antenna feedpoint.
- C. Tuning Button.** The Tuning Button is used to initiate an automatic tuning cycle.
- D. COMPLETE Indicator.** When the COMPLETE Indicator is lit red for one second, it means that tuning was successful. A quick red flash indicates a failure to tune.
- E. ERROR Indicator.** When the ERROR Indicator is lit red, it means the Coupler Unit TUNER connector is shorted. If this condition occurs, remove power from the Coupler Unit and check the coaxial cable between the Coupler Unit and Tuner Unit for a short.
- F. TUNER Indicator.** The TUNER Indicator will be lit green when power has been applied to the Coupler Unit.
- G. TUNER Connector.** The TUNER Connector is used to connect a coaxial cable from the Coupler Unit to the Tuner Unit. In addition to RF output, the Coupler Unit uses a bias-T circuit to send power and control signals to the remote Tuner Unit over the coaxial cable. Note: Do not connect any other devices between the Coupler Unit and Tuner Unit.
- H. TRANSMITTER Connector.** The TRANSMITTER Connector is used to connect a coaxial patch cable from the Coupler Unit to the transceiver.
- I. Power Connector.** The DC 12-14V 2A Power Connector is used to supply power to the Coupler Unit. The connector is a 5.5mm x 2.1mm coaxial connector, center pin positive (+).
- J. Power Switch.** When positioned in the “ON” position, the Power Switch energizes the URT1500 and enables operation. The URT1500 is de-energized when the position of the Power Switch is in the “OFF” position.
- K. Beehive Connector.** The Beehive Connector, marked “WIRE”, is an insulated standoff connection on the top of the Tuner Unit for connecting a single wire fed antenna. The Beehive Connector and Antenna Connector cannot be used at the same time. Do not use the Beehive Connector if using the Antenna Connector.
- L. Ground Connector.** The Ground Connector, labelled “GND”, is used to connect a ground or counterpoise wires.

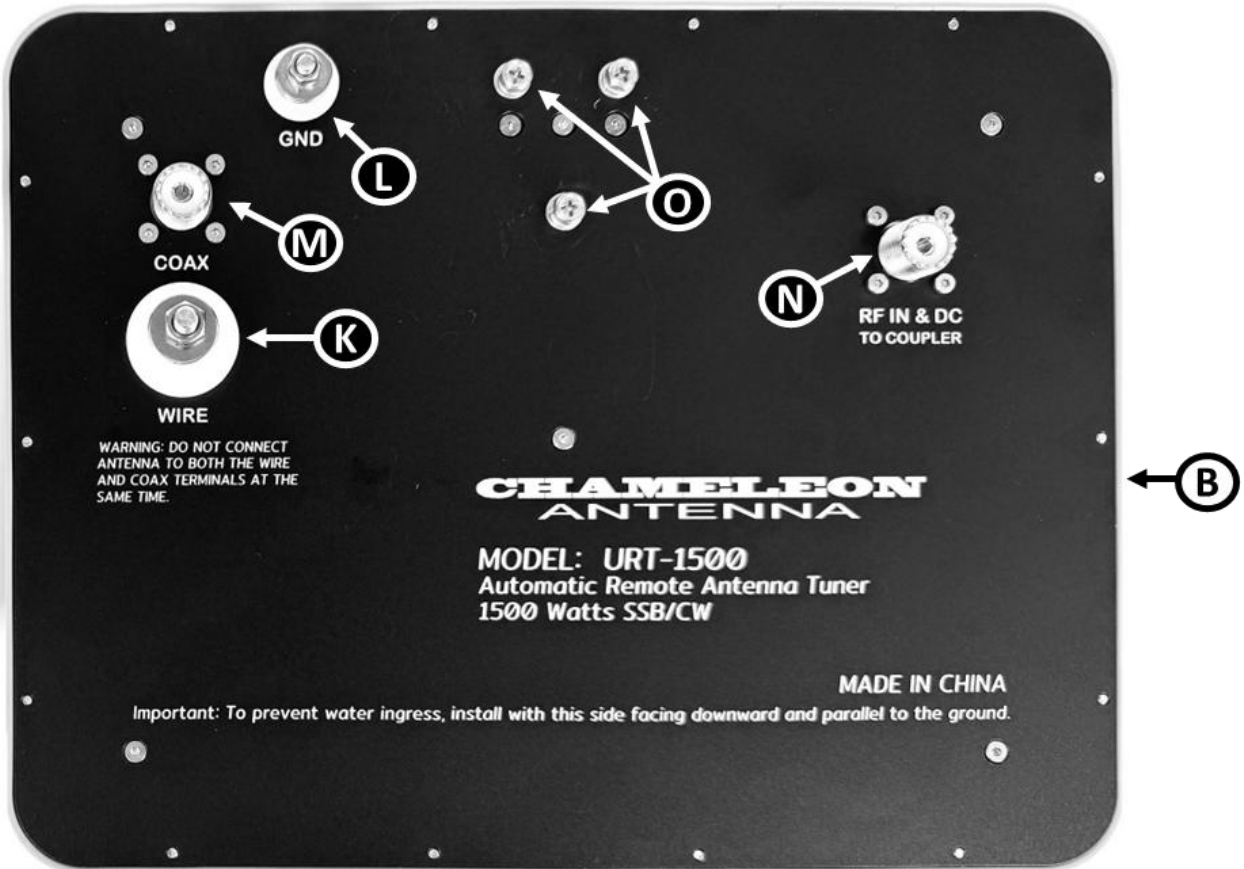

Plate 3. Tuner Unit.

- M. ANTENNA Connector.** The Antenna Connector, marked “COAX”, is used to connect a coaxial cable fed antenna. The Antenna Connector and the Beehive Connector cannot be used at the same time. Do not use the Antenna Connector if using the Beehive Connector.
- N. COUPLER Connector.** The COUPLER Connector, labelled “RF IN & DC TO COUPLER”, is used to connect a coaxial cable from the Tuner Unit to the Coupler Unit. Note: Do not connect any other devices between the Coupler Unit and Tuner Unit.
- O. Mount Points.** The Mount Points are located on the bottom of the Tuner Unit and are used to mechanically attach the Tuner Unit to the Mounting Bracket using the three screws provided.
- P. Mounting Bracket.** The Mounting Bracket attaches to the bottom of the Tuner Unit enabling mounting of the Tuner Unit on an outside mast, pipe, or post.
- Q. Pipe Clamps.** The Pipe Clamps are used to attach the Mounting Bracket to a mast or pipe.
- R. Power Cord.** The Power Cord supplies power to the Coupler Unit from your 12V power supply.

## Installation Options

The CHA URT1500 is designed to be used as a remote tuner. A remote tuner is where the Tuner Unit is installed outside near the antenna feedpoint, so loss due to high SWR on the feedline is avoided.

Attach the Mounting Bracket to the Tuner Unit at the Mount Points using the screws provided (*when shipped, the screws are already fastened to the Mounting Point holes*).

The Tuner Unit can be mounted outside using either a mast, pipe, or post. A stainless-steel bracket and pipe clamps are included to facilitate installation of the remote Tuner Unit outside.

**The Tuner Unit must be mounted facing down to avoid water intrusion.**

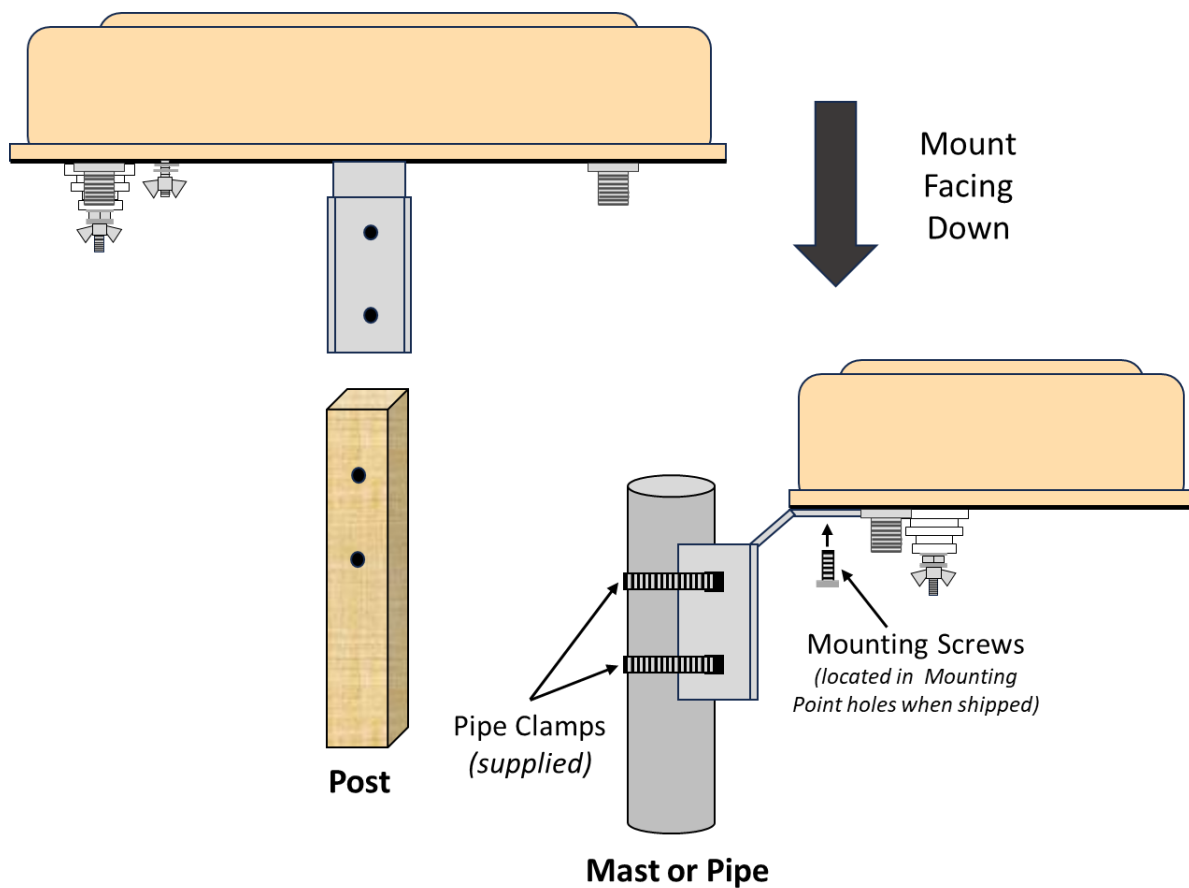
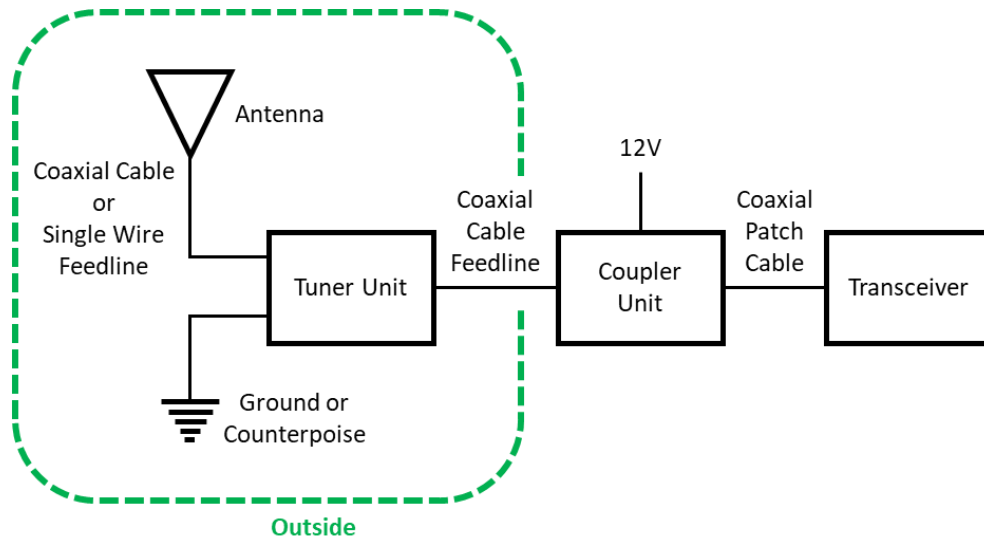

Figure 1. Tuner Mounting Options.

Figure (2) shows a block diagram of a remote tuner installation. **Do not connect any device (switch, diplexer, meter, etc.) between the Tuner Unit and Coupler Unit.**



**Figure 2. Remote Tuner Block Diagram.**

If the CHA URT1500 is replacing an existing local tuner or is going to be used with already installed coaxial cabling, the CHA URT1500 can be used as a local tuner. A local tuner is where the Tuner Unit is installed inside, near the Coupler Unit, as shown in figure (3). Only coaxial cable fed antennas can be used in a local tuner configuration. **Do not connect any device (switch, diplexer, meter, etc.) between the Tuner Unit and Coupler Unit.**

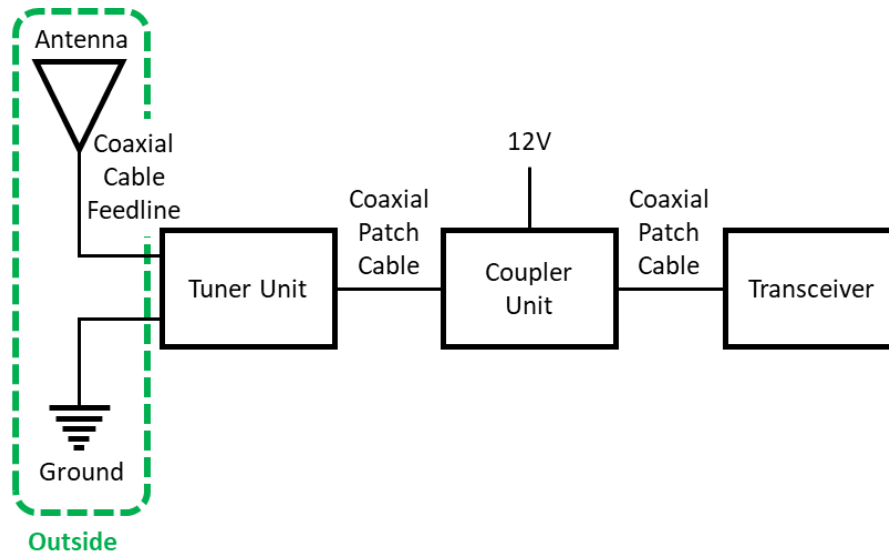

**Figure 3. Local Tuner Block Diagram.**



## Antenna Configurations

The CHA URT1500 can tune almost any single wire or coaxial fed antenna. Three typical configurations are shown below.

### Random Wire Antenna

The most popular antenna configuration used with remote tuners is a Random Wire Antenna, see figure (3). While any reasonable length wire will work, the key to best performance when installing a “random” length wire antenna is that it should not be a half-wavelength on any band you want to operate.

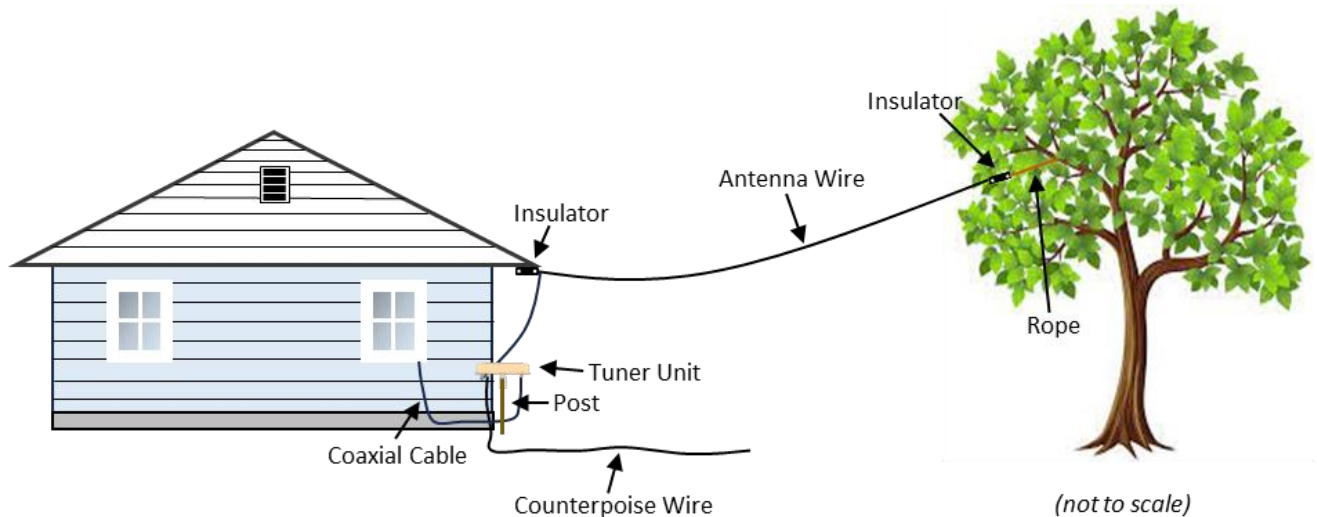

**Figure 3. Random Wire Antenna.**

According to one reference, the lengths under 150 feet that shouldn't be used are: 16, 19, 22, 26, 32, 33, 38, 44, 46, 48, 52, 64, 65, 66, 76, 78, 80, 88, 92, 95, 96, 99, 104, 110, 112, 114, 123, 128, 130, 132, 133, 138, and 144 feet. Search the Internet for “random wire antenna lengths” or see the ARRL Handbook for more information.

Install the Tuner Unit on a post or pipe outside near the feedpoint of the antenna. Connect the Antenna Wire to the Beehive Connector on bottom of the Tuner Unit. Do not use the ANTENNA Connector on the bottom of the Tuner Unit. Connect one or more Counterpoise Wires to the Ground Connector on the bottom of the Tuner Unit. The minimum length in feet of the Counterpoise Wire is shown in table (1). For example, if the lowest band you intend to operate on is 80 meters, the minimum length of the Counterpoise Wire(s) would be 27 feet. It is not necessary to have specific length (“tuned”) Counterpoise Wires.

Band	Length	Band	Length
160	52	17	5
80	27	15	4
60	18	12	4
40	13	10	3
30	9	6	2
20	7		

**Table 1. Minimum Counterpoise Wire Length.**

## Vertical Antenna

The CHA URT1500 is ideal for an all-band ground-mounted Vertical Antenna, as shown in figure (4). For example, the classic 43 foot Vertical Antenna will have excellent performance on 160-6 meters, when used with the CHA URT1500. Mount the Tuner Unit on a pipe or post near the base of the Vertical Antenna. Connect a wire from the Beehive Connector on the bottom of the Tuner Unit to the base of the Vertical Antenna. Use at least two Counterpoise Wires, opposite each other for 360° coverage. See table (1) for the minimum length of the Counterpoise Wires. It is not necessary to have specific length (“tuned”) Counterpoise Wires. Tuned elevated radials can also be used. Connect the Counterpoise Wires to the Ground Connector on the bottom of the Tuner Unit. Do not connect anything to the Tuner Unit ANTENNA Connector.

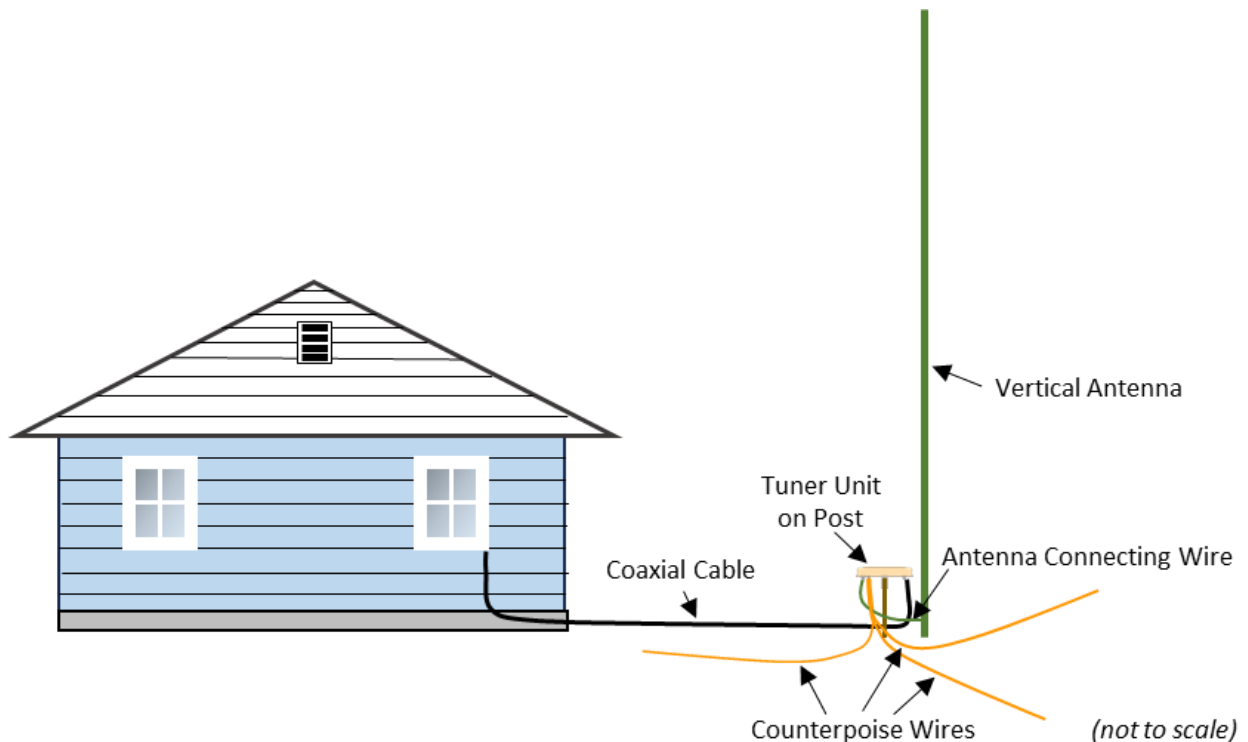

**Figure 4. Vertical Antenna.**

## Coaxial Fed Inverted "V" Antenna

The CHA URT1500 can also be used for tuning coaxial fed antenna, such as an Inverted "V" dipole antenna that has a BALUN in the center, like that shown in figure (5). The Tuner Unit should be located as close to the BALUN of the dipole as practicable, such as at the base of the mast. Connect the coaxial cable from the antenna BALUN to the ANTENNA Connector on the bottom of the Tuner Unit. Do not connect anything to the Beehive Connector of the Tuner Unit. A ground rod can be connected to the Ground Connector on the bottom of the Tuner Unit.

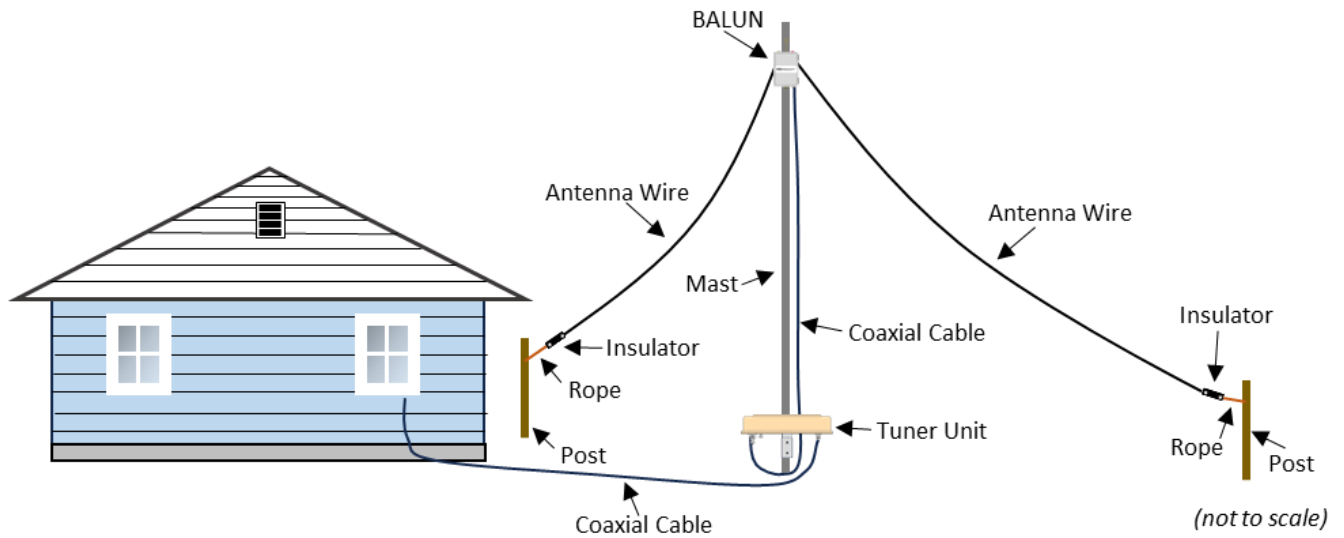

Figure 5. Inverted "V" Dipole Antenna.

## Tuner Connections

Connecting the CHA URT1500 is easy since transceiver-specific control cables are not required. The CHA URT1500 can be used to tune single wire fed or coaxial cable fed antennas. Figure (6) shows the connections necessary for a single wire antenna. Figure (7) shows the connections necessary for a coaxial cable fed antenna.

Connect the antenna connection from the Amplifier or Transceiver to the “TO TRANSMITTER” connector on the back of the Coupler Unit. Connect the “TO TUNER” connector from the Coupler Unit to the “RF IN & DC TO COUPLER” connector on the bottom of the Tuner Unit. Connect the antenna to the “COAX” or “WIRE” connector on the bottom of the Tuner Unit, as applicable. Using the supplied power cable, connect a power supply capable of providing 12V DC at 2.0A to the “DC” connector on the back of the Coupler Unit.

When installing coaxial connectors outside, be sure to use a good quality weatherproof sealing tape, such as *Coax-Seal*<sup>(R)</sup>. Also, ensure the Tuner Unit is mounted facing down when installed outside, as shown in figure (3).

- The coaxial cable between the Coupler Unit and the Tuner Unit has 12V DC power applied to it by the Coupler Unit bias-T circuit, be sure the coaxial cable is connected to the correct connectors on both units.
- For the same reason, do not connect any device (switch, diplexer, meter, etc.) between the Tuner Unit and Coupler Unit. Any such device could short out the 12V DC power on the coaxial cable, damage the tuner, and void the warranty. Electrical or electronic devices should be connected between the Transceiver and the Coupler Unit.

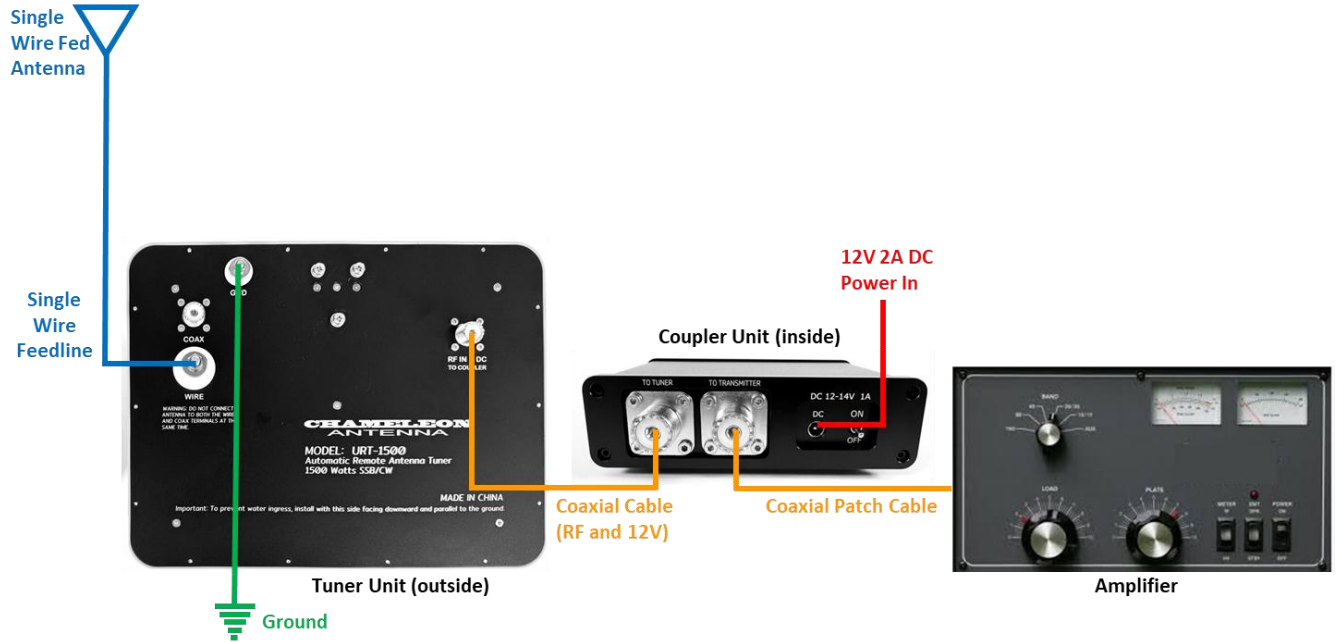

Figure 6. Single Wire Antenna Tuner Connections.

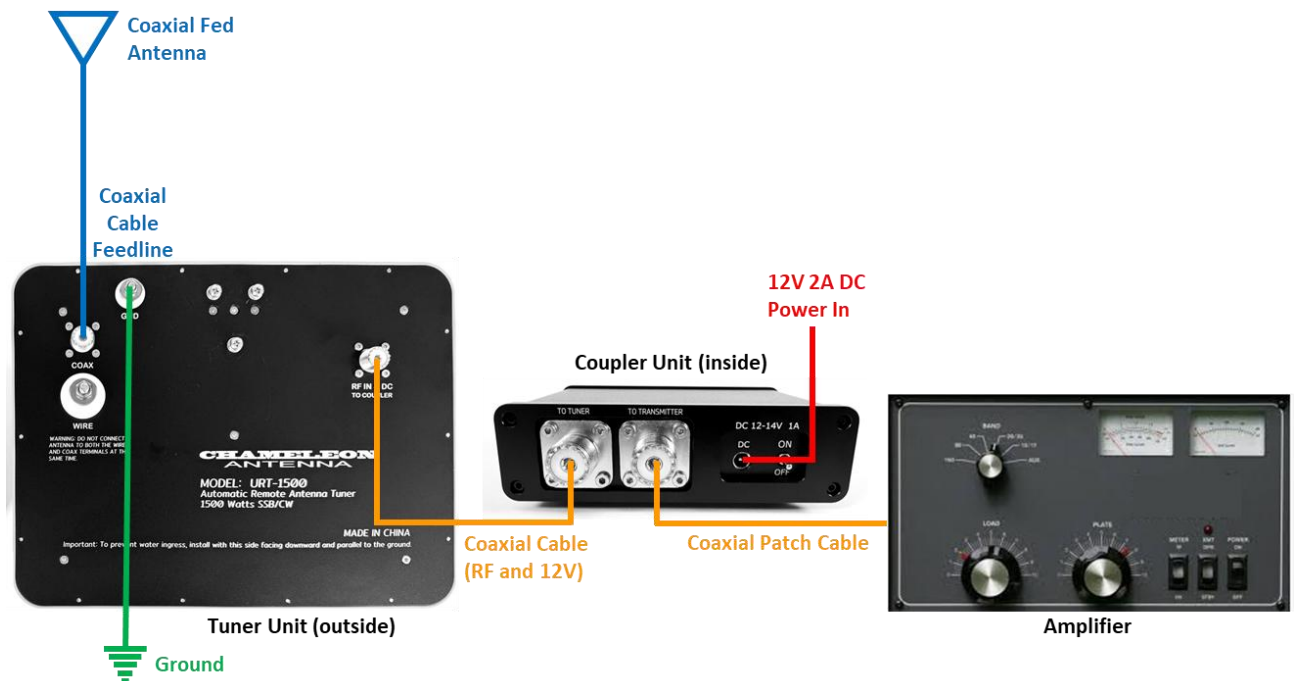

Figure 7. Coaxial Fed Antenna Tuner Connections.

## Tuner Operation

Operation of the CHA URT1500 is one-button easy. To tune the antenna, perform the following steps (see figure [8]):

1. Ensure the Tuner is connected. The TUNER indicator light will be lit green when power is applied to the Coupler Unit and the unit is turned on.
2. Set the transceiver to the frequency on which you want to operate.
3. If your transceiver has an internal antenna tuner, ensure it is turned off or bypassed.
4. Set the mode to CW with a straight key or the internal keyer set to straight key. Alternatively, use FM, AM, or RTTY modes. The objective is to transmit a constant power output.
5. Set power level to any value from 5 to 15 Watts.
6. Briefly press or tap the "TUNING" button.
7. Immediately key the transmitter so it produces a constant power output. Unkey the transmitter when the tuning cycle completes (eight seconds or less). The COMPLETE Indicator will illuminate red for one second if tuning was successful. A quick red flash indicates a failure to tune. You can also watch the Transceiver SWR meter and it will show a low SWR when the tuning cycle has successfully completed.

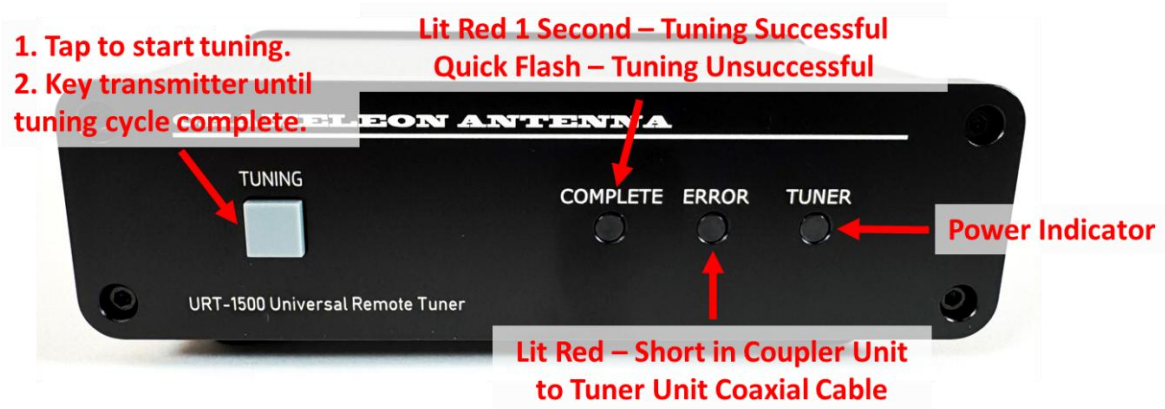

Figure 8. Coupler Unit Operation.

### Tuning Notes:

1. The seven-step tuning procedure above must be executed whenever the Coupler Unit is powered on.
2. The seven-step tuning procedure above should be executed whenever changing to a frequency causes the SWR to be higher than acceptable to you (e.g. 1.5:1).
3. An automatic tuning cycle or memory recall will not be initiated by tapping the TUNING button without keying the transmitter or keying the transmitter without tapping the

TUNING button. You should follow the steps in the seven-step procedure to initiate the automatic tuning cycle of the URT1500.

4. When executing the seven-step tuning procedure above, a normal tuning cycle should take around 8 seconds (not including the time it takes you to change the mode and power level of your transmitter). If the frequency sensor is able to match the transmitted frequency to one stored in the URT1500's memory, the tuning cycle may be reduced to as little as 0.1 seconds.
5. Tuning is complete and successful when the COMPLETE light illuminates red for one second and the SWR on your transceivers meter is low.

A quick red flash of the COMPLETE light or a high SWR on your transceivers meter indicates tuning was unsuccessful – retry the seven-step tuning procedure.

## **Troubleshooting**

1. Ensure power is turned on and the “TUNER” light is lit green. If not, ensure that a power supply, capable of supplying between 12.0-14.0V 2.0A DC, has been connected to the Power Connector of the Coupler Unit and that the Power Switch is turned ON. Ensure supplied power does not exceed 14.0V.
2. If the “ERROR” indicator is lit a steady red color, it indicates the coaxial cable between the Coupler Unit and the Tuner Unit has a short. Immediately remove power from the Coupler Unit. Replace or repair the coaxial cable between the Coupler Unit and the Tuner Unit. Make sure there are no devices (switch, diplexer, meter, etc.) connected between the Tuner Unit and Coupler Unit.
3. Ensure all connections are correct per figures (6) and (7).
4. Inspect antenna components, especially the coaxial cables, for indications of damage. Replaced damaged components. Most problems with antennas are caused by coaxial cables and connectors.
5. Be sure to check any patch cables or adapters used.
6. If your transceiver has an internal antenna tuner, ensure it is turned off or bypassed.
7. If still not operational, contact Chameleon Antenna™ for technical support.

## Specifications

- **Frequency Range:** 1.8 to 30.0 MHz.
- **Power Handling:** 1500W SSB/CW; 800W most digital and non-continuous duty modes; 400W AM, RTTY, WSPR and other similar continuous duty modes.
- **Tuning Power Range:** 5 – 15 Watts.
- **Tuning Ratio Range:** 16:1.
- **Tuning Time:** 8 Seconds for full tune, 0.1 Seconds for memory tune.
- **Memory:** 16,000 frequencies with built in frequency sensor.
- **Power Supply:** 12.0-14.0V DC, 2.0A (Do not exceed 14.0V. Voltage higher than 14.0V may cause damage to Coupler and Tuner Units)
- **Temperature Range:** Approximately 14°F (10C) to 140°F (60C).
- **Coupler Unit Dimensions:** 5 x 5 x 4.1 x 1.7 inches (128 x 105 x 43mm)
- **Coupler Unit Weight:** 14.1 oz (400g)
- **Tuner Unit Dimensions:** 11.8 x 9.2 x 3.7 inches (300 x 234 x 93mm)
- **Tuner Unit Weight:** 4.6 lbs. (2.1 Kg)



## Chameleon Antenna™ Products

Go to <http://chameleonantenna.com> for information about quality antenna products available for purchase from Chameleon Antenna™ – The Portable Antenna Pioneer.

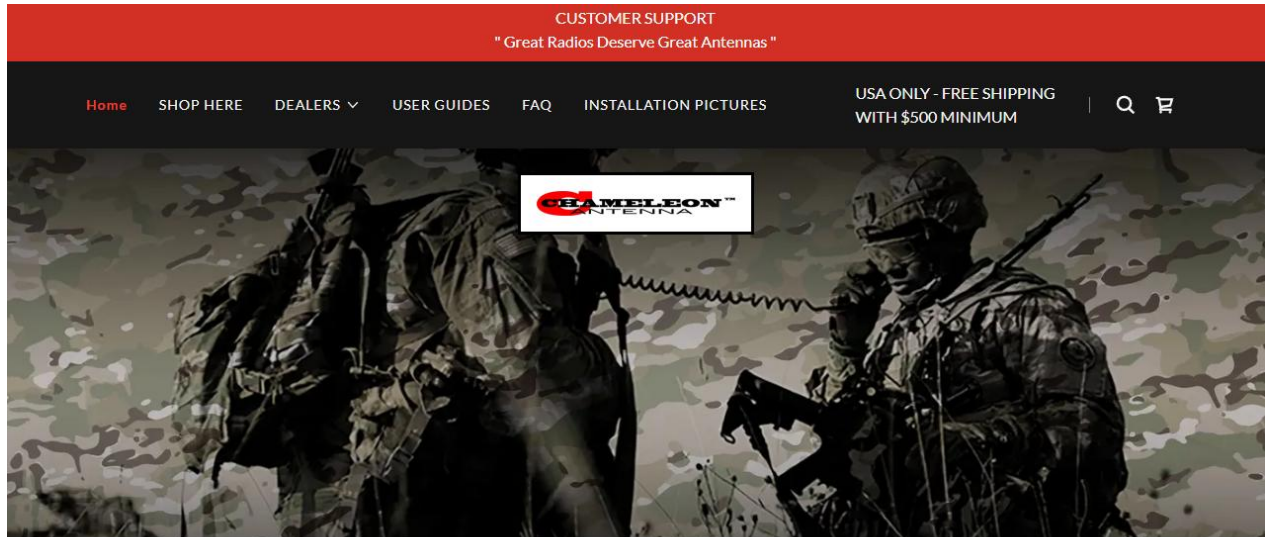

## THE PORTABLE ANTENNA PIONEER BECAUSE GREAT RADIOS DESERVE GREAT ANTENNAS

Chameleon Antenna™ products are available from these great dealers:

HRO  
DX ENGINEERING  
GIGAPARTS  
WIMO  
MOONRAKER  
RADIOWORLD UK  
R&L ELECTRONICS  
ML&S MARTIN LYNCH  
PILEUPDX  
LUTZ-ELECTRONICS  
RADIOWORLD CANADA  
GPS CENTRAL  
PASSION-RADIO.COM